

LV91

NAPLES

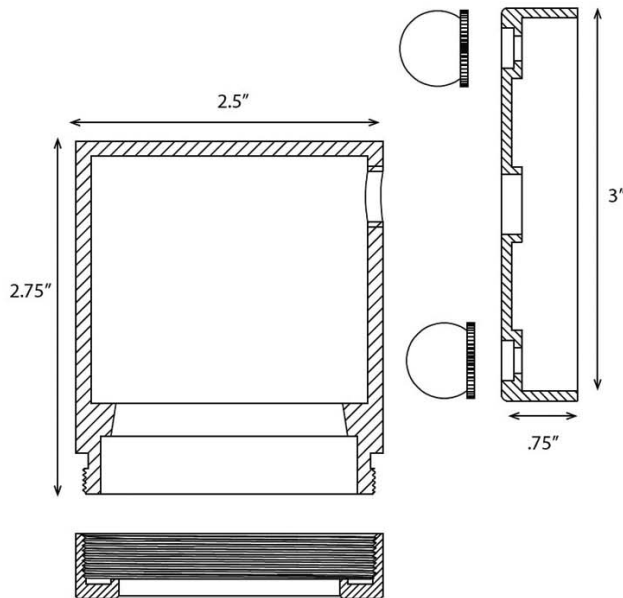

FINISHES



BULB	MR16	CONSTRUCTION	DIE CAST BRASS
MAX WATTAGE	50W	IP CODE	65
POWER	12V TRANSFORMER	WEIGHT	2.5 LBS
BULK BOX QUANTITY	10	BULK BOX WEIGHT	25 LBS
HEIGHT	5"	WIRING	18" OF #18-2, SPT-1W LEADS
DEPTH	3.5"	WARRANTY	LIFETIME
WIDTH	2.5"	FEATURES	SHINES DOWN