



landscape • entertainment • architectural • hospitality • illumination

NEW

SL-16-MR16 UP/DOWN LIGHTS



25301 COMMERCENTRE DRIVE • LAKE FOREST, CA 92630 • 949.830.1350 • 888.882.1350 • FAX 949.830.3390



WALL MOUNT UP/DOWN SL-16-MR16



TYPE



SPECIFICATIONS

- CONSTRUCTION:** 316 stainless steel or brass; cylinder and canopy
- LENS:** Clear tempered flat glass
- CANOPY GASKET:** Black newsponge closed cell .190" thickness
- LAMP SUPPLIED:** 2 x 20 watt MR16 FL(BAB) 5000 hours average rating (40w total max)
- LAMP OPTIONS:** We recommend 40,000 hour ARROW Super Saver LEDs:
3w LED (-LED3) 5w (-LED5) or 7w (-LED7)
- SOCKET:** High temperature ceramic GU5.3 bi-pin with 250°C silicone lead wires
- WIRING:** Black and 2 White 250°C silicone lead wires
- CONNECTION:** FA-05 Quick Connector (not supplied) from fixture to main cable (12/2, 10/2 or 8/2 only)
- MOUNTING:** Canopy included with 2 stainless steel or brass #2 Phillips, flat head, wood screws
- FINISH:** Stainless Steel-Machined stainless steel only
Brass-Unfinished brass. Optional finishes available



SL16-MR16-SS



SL16-MR16-ETC-BRS

DOWN LIGHT MODEL AVAILABLE SEE SL-16-DMR16

ORDERING INFORMATION

CATALOG NO.	DESCRIPTION	LAMP	SHIP WEIGHT
SL-16-MR16-SS	316 Stainless Steel Up/Down Light	2 X 20w MR16 FL	2.0 lbs.
SL-16-MR16-24LG-SS	316 Stainless Steel Up/Down Light w/FA-24LG canopy	2 X 20w MR16 FL	2.0 lbs.
SL-16-MR16-BRS	Brass Up/Down Light	2 X 20w MR16 FL	2.0 lbs.
SL-16-MR16-24LG-BRS	Brass Up/Down Light w/FA-24LG canopy	2 X 20w MR16 FL	2.0 lbs.
SL-16-MR16-ETC-BRS	Brass Up/Down Light	2 X 20w MR16 FL	3.0 lbs.
SL-16-MR16-ETC-24LG-BRS	Brass Up/Down Light w/FA-24LG canopy	2 X 20w MR16 FL	3.0 lbs.

COLOR/BEAM/GLARE CONTROL ACCESSORIES

- FA-08-21** Round 1/8" Black Hex Cell Louver
- FA-11-BLUE** Blue Tempered Flat Glass Lens
- FA-11-GREEN** Green Tempered Flat Glass Lens
- FA-11-AMBER** Amber Tempered Flat Glass Lens
- FA-11-RED** Red Tempered Flat Glass Lens
- FA-104-SB** Wide Spread Sand Blasted Glass Lens

LIGHT DISTRIBUTION AND PHOTOMETRICS

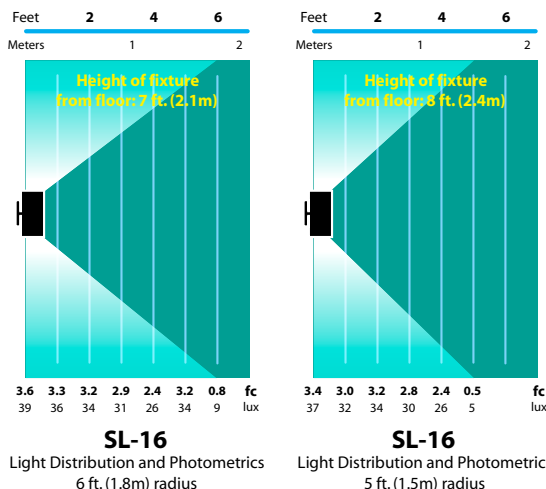

JOB INFORMATION	
Type:	Date:
Job Name:	
Cat. No.:	
Lamp(s):	
Specifier:	
Contractor:	
Notes:	
FOCUS INDUSTRIES INC. 25301 COMMERCENTRE DRIVE LAKE FOREST, CA 92630	
www.focusindustries.com sales@focusindustries.com (949) 830-1350 • FAX (949) 830-3390	

Black Texture (Standard)	Antique Verde	Bronze Texture	Camel	White Texture	Hunter Texture	Rust	Weathered Iron	Weathered Brown	Stucco	Rubbed Verde	Chrome Powder	Acid Rust	Acid Verde	Black Acid Treatment
-BLT	-ATV	-BRT	-CAM	-WTX	-HTX	-RST	-WIR	-WBR	-STU	-RBV	-CPR	-BAR/CAR	-BAV/CAV	-BAT



WALL MOUNT UP/DOWN SL-16-MR16

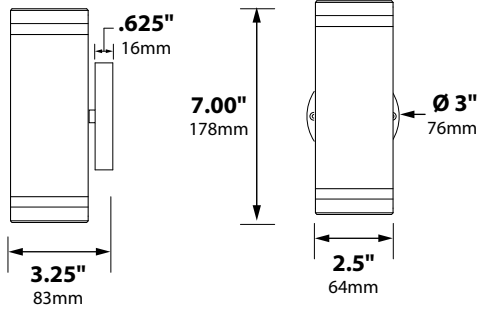

SL16-MR16

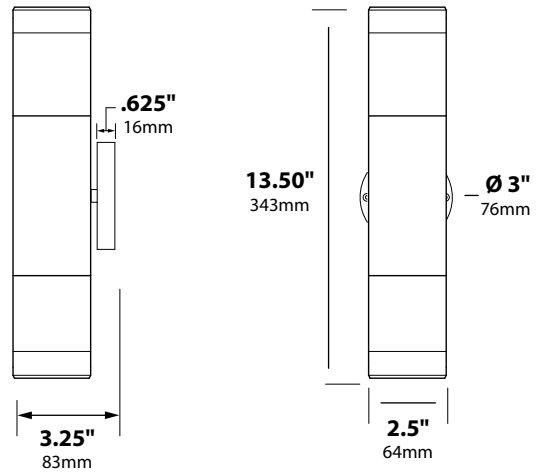

SL16-MR16-ETC

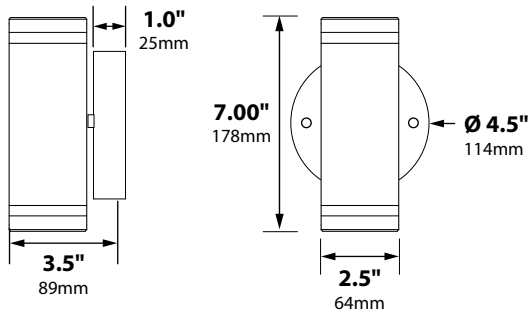

SL16-MR16-24LG

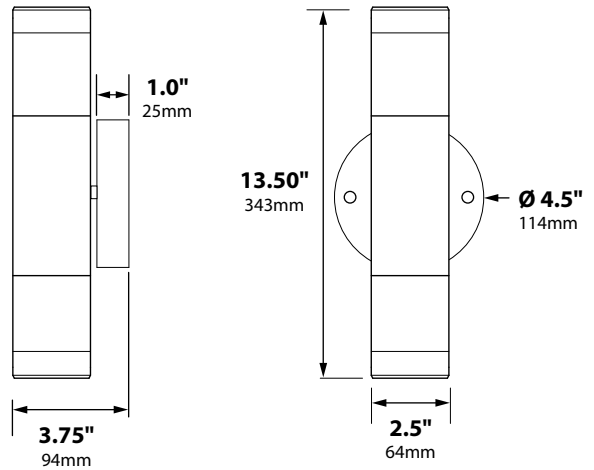

SL16-MR16-ETC-24LG