



### Orbital: 12V Suspended Light

PROJECT:	
TYPE:	
CATALOG NUMBER:	
LAMP(S):	
NOTES:	

### FIXTURE ORDERING INFORMATION

Example: ORBI-NL-BK (Orbital, No Lamp, Black)

MODEL NAME	WATTAGE	FINISH
ORBI	NL = No Lamp	BK = Black BZ = Bronze

### DIMENSIONS:

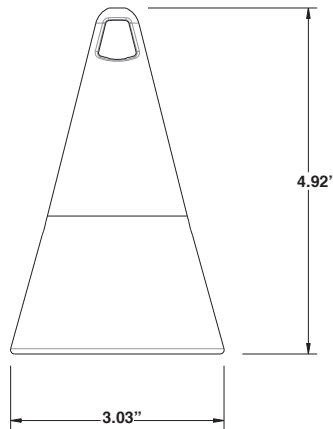

**FLEX™** Unique Lighting Systems® fixtures are compatible with **FLEX™** Series LEDs. **FLEX™** Series LED lamps can be ordered separately.

Only available with the NL wattage option. Unique Lighting Systems® reserves the right to modify the design and/or construction of the fixture shown without further notification.

### SPECIFICATIONS

#### Our Commitment

Unique Lighting Systems' highest commitment is to set the standard for manufacturing innovative and quality products. This commitment is evident through our detailed inspection processes and extensive field testing. From the initial design process of each product, to the final assembly of each custom-made individual part, our manufacturing process accomplishes the highest level of performance and durability carried through to final delivery to the end user. Durable construction and beautiful styling make Unique™ fixtures the ideal solution for any residential or commercial application. Unique Lighting™ already holds numerous product patents and we are constantly developing innovative ideas to help expand the lighting industry.

#### Body

Precision machined from Marine grade A360 alloy. Body design provides enclosed, water resistant wireway to protect wires.

#### Gasket

High temperature silicone o-rings for water-tight seal.

#### Shroud

Precision machined marine grade A360 alloy.

#### Lens

Flat clear tempered glass. Patented removeable lens. The fully gasketed lens is held in place with a threaded lens retainer.

#### Lamp

For use with **FLEX™** Series LED lamps available in 2W MR11. LED lamps are available in 2700K and 3000K color temperatures. Halogen lamp up to 20W MR11 lamp.

#### Electrical Requirements

A remote 12V transformer required, may be ordered separately from Unique Lighting Systems®. Voltage range for 12V halogen lamps is 10.8V to 12V. Voltage range for **FLEX™** Series LED MR11 lamps is 10V-15V.

#### Lamp Connection

Specification grade, nickel lamp holder. GU5.3 base.

#### Wiring

15' 18/2 wire lead. Pre-stripped Hub-ready leads for quick installation.

#### Finish

E-Shield™ is the Elements™ Series five stage coating process that bonds base material with corrosion-resistant processes and finishes it with an extremely durable, polyester powder coat paint.

#### Warranty

The Elements™ Series of products from Unique Lighting Systems® carries a 10 year warranty against manufacturer's defects.

#### Manufacturing

Manufactured to ISO 9001-2008 Quality Systems Standard.



Conforms to UL 2108  
CSA C22.2 No. 9