



**PROFESSIONAL  
OUTDOOR LIGHTING**

Type: \_\_\_\_\_

Model: \_\_\_\_\_

Project: \_\_\_\_\_

# SPECIFICATION SHEET

## MODEL 4015 Landscape Series • Specialty Lights

### FIXTURE SPECIFICATIONS:

**HOUSING:**

Heavy gauge extruded aluminum.

**STEM:**

Heavy gauge, adjustable, nickel plated stainless steel tubing.

**FINISH:**

Black polyester powder-coat finished housing & base with black UV resistant PVC incased stem.

**SOCKET/LAMP HOLDER:**

Top grade ceramic socket with nickel contacts, stainless steel springs, & Teflon-jacketed wire leads.

**LENS:**

Shock & heat resistant soda-lime glass lens.

**LAMP TYPE:**

- MR-16 Halogen – 20W maximum. LN-20 BAB (20W) Standard.
- MR-16 LED Lamp - 36° Flood, 4.5W is standard.

**MOUNTING:**

Bottom of stem threaded into CNC-machined solid aluminum mounting canopy.

**FASTENERS:**

All fasteners are stainless steel.

**WIRING:**

Prewired with a 3' pigtail of 18-2 direct-burial cable & underground connectors for a secure connection to supply cable. Optional hardwired on/off switch available.

All Vista luminaires are **MADE IN U.S.A.**

### DIMENSIONS:

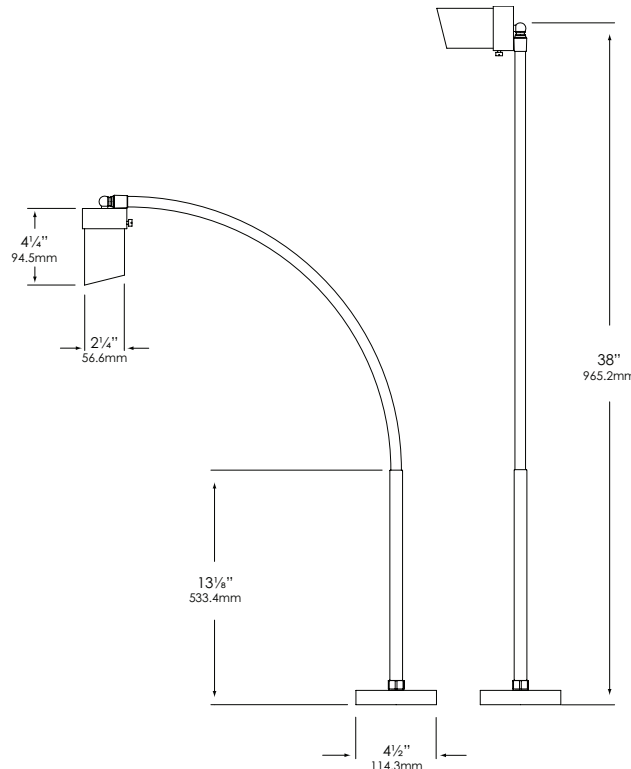

*Vista Professional Outdoor Lighting reserves the right to modify the design and/or construction of the fixture shown without further notification.*



## SPECIFICATION SHEET

### MODEL 4015 Landscape Series • Specialty Lights

#### FIXTURE ORDERING INFORMATION

TO ORDER FIXTURE: Select appropriate choice from each column as in the following example.

**EXAMPLE: FL-4015-B-BAB-SL**

MOUNTING	MODEL	FINISH	LAMP	ACCESSORIES
FL - Flexible stem with solid CNC-machined aluminum mounting base	4015	B - Black	MR-16 Halogen 20W maximum LN-20 BAB (20W) Standard  LED MR-16 4.5 W LN16-4.5-W-36-LED  <i>(Please see lamp order code column on lamp guide, Vista product catalog.)</i>	BL - Flat Cool Blue lens SL - Flat Spread lens FR - Flat Frosted lens DBL - Flat Dark Blue lens GL - Flat Dark Green lens RL - Flat Red lens YL - Flat Amber lens

Fixtures shipped with standard lamp, unless otherwise specified.