

# CANOPY 6" LED AREA LIGHT

6053

# WAC

## LANDSCAPE LIGHTING

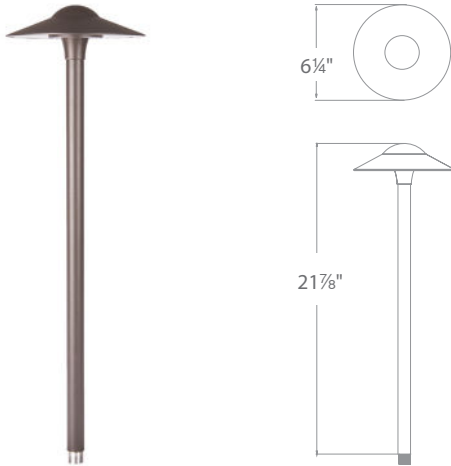

Fixture Type:

Catalog Number:

Project: \_\_\_\_\_

Location: \_\_\_\_\_

### PRODUCT DESCRIPTION

Sturdy side mount design works well in applications where directional illumination is desired

### SPECIFICATIONS

**Input:** 9-15VAC (Transformer is required)  
**Power:** 6.5W / 9.5VA  
**Brightness:** Up to 225 lm  
**CRI:** 90+  
**Rated Life:** 60,000 hours

### FEATURES

- IP66 rated, Protected against powerful water jets
- Factory sealed water tight fixtures
- Solid brass or corrosion resistant aluminum alloy
- Recommended spacing for installation: Residential: 7 to 9ft; Commercial: 5 to 7ft
- Mounting stake, 6 foot lead wire, and direct burial gel filled wire nuts are included
- Maintains constant lumen output against voltage drop
- UL & cUL 1838 Listed

### ORDERING NUMBER

		Color Temp	Finish	
6053	Canopy	27	2700K Warm White	
		30	3000K Pure White	
		BBR	Bronze on Brass	
			BZ	Bronze on Aluminum
			BK	Black on Aluminum

6053-\_\_\_BK

Example: 6053-30BK

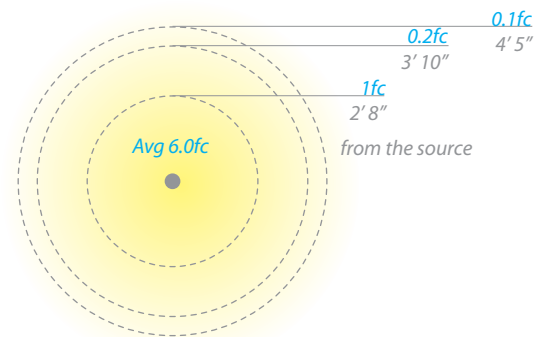

wacighting.com  
 Phone (800) 526.2588  
 Fax (800) 526.2585

Headquarters/Eastern Distribution Center  
 44 Harbor Park Drive  
 Port Washington, NY 11050

Central Distribution Center  
 1600 Distribution Ct  
 Lithia Springs, GA 30122

Western Distribution Center  
 1750 Archibald Avenue  
 Ontario, CA 91760

# CANOPY 6" LED AREA LIGHT

6053

# WAC

## LANDSCAPE LIGHTING

### Surface Mount Flange/Stake



*Includes three 7 inch threaded stainless steel stabilizing pins for ground mounting or surface mounts with four screws or over a junction box*

**5000-SCP-BZ**  
*Bronze on Aluminum*

### Additional Mounting Stake



**9000-ST9-BZ**  
*Durable PVC stake*



### Guardian Mount

*Heavy duty stainless steel spike to position fixture.  
Formed from a single piece of metal*

**9000-SP9-BZ**  
*Stainless Steel*

### Magnetic Transformers

*Stainless Steel, 12-15V output, IP65 rated, UL 1838 listed  
See transformer spec sheet for details and its accessories*

**9075-TRN-SS**  
*75W Max*

**9150-TRN-SS**  
*150W Max*

**9300-TRN-SS**  
*300W Max*

**9600-TRN-SS**  
*600W Max*



waclighting.com  
Phone (800) 526.2588  
Fax (800) 526.2585

Headquarters/Eastern Distribution Center  
44 Harbor Park Drive  
Port Washington, NY 11050

Central Distribution Center  
1600 Distribution Ct  
Lithia Springs, GA 30122

Western Distribution Center  
1750 Archibald Avenue  
Ontario, CA 91760

*WAC Lighting retains the right to modify the design of our products at any time as part of the company's continuous improvement program.*