

BALANCE DOUBLE LED PATH LIGHT

6071

WAC

LANDSCAPE LIGHTING

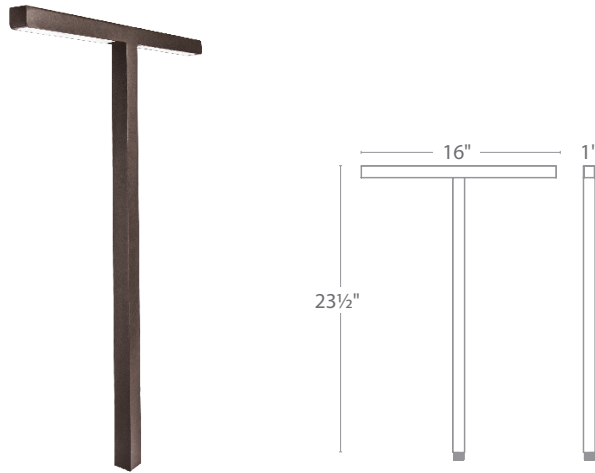

Fixture Type:

Catalog Number:

Project: _____

Location: _____

PRODUCT DESCRIPTION

Sleek linear design blends seamlessly into pathways while providing soft, even illumination

SPECIFICATIONS

Input: 9-15VAC (Transformer is required)
Power: 10.0W / 14VA
Brightness: 375 lm
CRI: 90
Rated Life: 60,000 hours

FEATURES

- IP66 rated, Protected against powerful water jets
- Factory sealed water tight fixtures
- Solid diecast corrosion resistant aluminum alloy
- Recommended spacing for installation: Residential 11 to 13ft; Commercial: 7 to 13ft
- Mounting stake, 6 foot lead wire, and direct burial gel filled wire nuts are included
- Maintains constant lumen output against voltage drop
- UL & cUL 1838 Listed

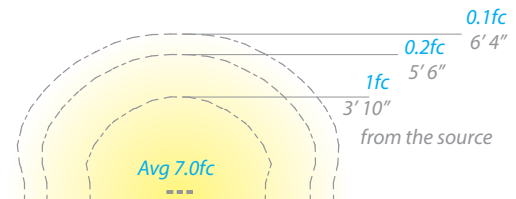

ORDERING NUMBER

		Color Temp	Finish
6071	Double Balance	27 2700K Warm White	BZ Bronze on Aluminum
		30 3000K Pure White	BK Black on Aluminum

6071-___BZ

Example: **6071-30BZ**

wacighting.com
 Phone (800) 526.2588
 Fax (800) 526.2585

Headquarters/Eastern Distribution Center
 44 Harbor Park Drive
 Port Washington, NY 11050

Central Distribution Center
 1600 Distribution Ct
 Lithia Springs, GA 30122

Western Distribution Center
 1750 Archibald Avenue
 Ontario, CA 91760

WAC Lighting retains the right to modify the design of our products at any time as part of the company's continuous improvement program.

BALANCE DOUBLE LED PATH LIGHT

6071

WAC

LANDSCAPE LIGHTING

Surface Mount Flange/Stake



Includes three 7 inch threaded stainless steel stabilizing pins for ground mounting or surface mounts with four screws or over a junction box

5000-SCP-BZ
Bronze on Aluminum

Additional Mounting Stake



9000-ST9-BK
Durable PVC stake

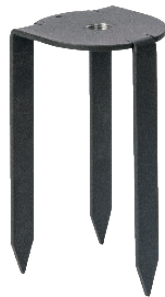

Guardian Mount

*Heavy duty stainless steel spike to position fixture.
Formed from a single piece of metal*

9000-SP9-BZ
Stainless Steel

Magnetic Transformers

*Stainless Steel, 12-15V output, IP65 rated, UL 1838 listed
See transformer spec sheet for details and its accessories*

9075-TRN-SS
75W Max

9150-TRN-SS
150W Max

9300-TRN-SS
300W Max

9600-TRN-SS
600W Max



waclighting.com
Phone (800) 526.2588
Fax (800) 526.2585

Headquarters/Eastern Distribution Center
44 Harbor Park Drive
Port Washington, NY 11050

Central Distribution Center
1600 Distribution Ct
Lithia Springs, GA 30122

Western Distribution Center
1750 Archibald Avenue
Ontario, CA 91760

WAC Lighting retains the right to modify the design of our products at any time as part of the company's continuous improvement program.