

# INTERPATH LED AREA LIGHT

6511

# WAC

## LANDSCAPE LIGHTING

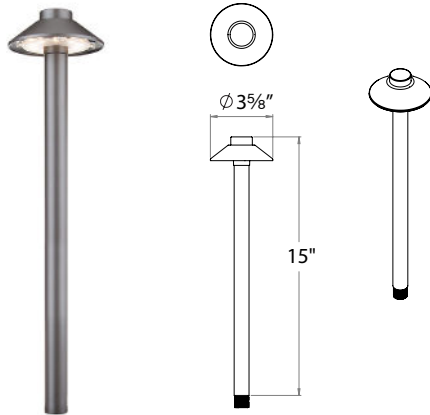

Fixture Type:

Catalog Number:

Project: \_\_\_\_\_

Location: \_\_\_\_\_

### PRODUCT DESCRIPTION

Sturdy center mount design works well in applications where area illumination is desired. Simple design with small form factor, natural fit to any landscapes.

### SPECIFICATIONS

**Input:** 9-15VAC (Transformer is required)  
**Power:** 2.5W / 2.7VA  
**Brightness:** Up to 100 lm  
**CRI:** 90+  
**Rated Life:** 60,000 hours

### FEATURES

- IP66 rated, Protected against powerful water jets
- Factory sealed water tight fixtures
- Solid diecast corrosion resistant aluminum alloy
- Recommended spacing for installation: Residential: 4 to 6 ft; Commercial: 3 to 4ft
- Mounting stake, 6 foot lead wire, and direct burial gel filled wire nuts are included
- Maintains constant lumen output against voltage drop
- UL & cUL 1838 Listed

### ORDERING NUMBER

		Color Temp	Finish
6511	Interpath	27 2700K Warm White	<b>BBR</b> Bronze on Brass
		30 3000K Pure White	<b>BZ</b> Bronze on Aluminum <b>BK</b> Black on Aluminum

6511-\_\_\_BK

Example: 6511-30BK

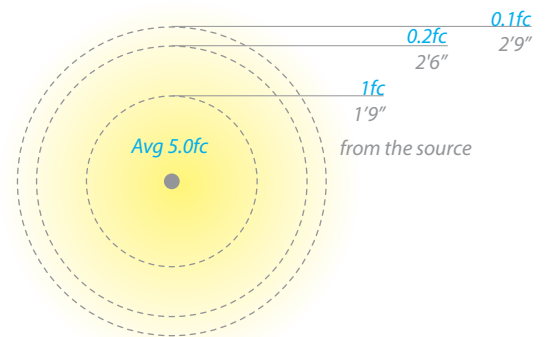

wacighting.com  
 Phone (800) 526.2588  
 Fax (800) 526.2585

Headquarters/Eastern Distribution Center  
 44 Harbor Park Drive  
 Port Washington, NY 11050

Central Distribution Center  
 1600 Distribution Ct  
 Lithia Springs, GA 30122

Western Distribution Center  
 1750 Archibald Avenue  
 Ontario, CA 91760

# INTERPATH LED AREA LIGHT

6511

# WAC

## LANDSCAPE LIGHTING

### Surface Mount Flange/Stake



*Includes three 7 inch threaded stainless steel stabilizing pins for ground mounting or surface mounts with four screws or over a junction box*

#### **5000-SCP-BZ**

*Bronze on Aluminum*



### Guardian Mount

*Heavy duty stainless steel spike to position fixture.  
Formed from a single piece of metal*

#### **9000-SP9-BZ**

*Stainless Steel*

### Additional Mounting Stake



#### **9000-ST9-BK**

*Durable PVC stake*

### Magnetic Transformers

*Stainless Steel, 12-15V output, IP65 rated, UL 1838 listed  
See transformer spec sheet for details and its accessories*

#### **9075-TRN-SS**

*75W Max*

#### **9150-TRN-SS**

*150W Max*

#### **9300-TRN-SS**

*300W Max*

#### **9600-TRN-SS**

*600W Max*



[wacighting.com](http://wacighting.com)

Phone (800) 526.2588

Fax (800) 526.2585

**Headquarters/Eastern Distribution Center**

44 Harbor Park Drive

Port Washington, NY 11050

**Central Distribution Center**

1600 Distribution Ct

Lithia Springs, GA 30122

**Western Distribution Center**

1750 Archibald Avenue

Ontario, CA 91760

*WAC Lighting retains the right to modify the design of our products at any time as part of the company's continuous improvement program.*