

# SLIDE LED PATH LIGHT

6311

# WAC

## LANDSCAPE LIGHTING

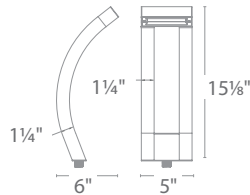

Fixture Type:

Catalog Number:

Project: \_\_\_\_\_

Location: \_\_\_\_\_

### PRODUCT DESCRIPTION

Sleek linear design blends seamlessly into pathways while providing soft, even illumination

### FEATURES

- IP66 rated, Protected against powerful water jets
- Factory sealed water tight fixtures
- Translucent lens provides uniform light distribution
- Constant output for 9V-15V input
- Mounting stake, 6 foot lead wire, and direct burial gel filled wire nuts are included
- Recommended spacing for installation: Residential: 7 to 9ft; Commercial: 4 to 6ft
- Maintains constant lumen output against voltage drop
- UL & cUL 1838 Listed (12V)

### SPECIFICATIONS

- Input:** 9-15VAC (Transformer is required)
- Power:** 3.0W / 4.5VA
- Brightness:** Up to 95 lm
- CRI:** 90
- Rated Life:** 60,000 hours

### ORDERING NUMBER

	Color Temp	Finish
<b>6311</b> <i>Small Slide</i>	<b>30</b> <i>3000K Pure White</i>	<b>BZ</b> <i>Bronze on Aluminum</i>

**6311-\_\_\_BZ**

Example: **6311-30BZ**

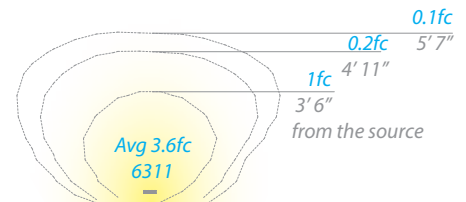

wacighting.com

Phone (800) 526.2588

Fax (800) 526.2585

Headquarters/Eastern Distribution Center

44 Harbor Park Drive

Port Washington, NY 11050

Central Distribution Center

1600 Distribution Ct

Lithia Springs, GA 30122

Western Distribution Center

1750 Archibald Avenue

Ontario, CA 91760

WAC Lighting retains the right to modify the design of our products at any time as part of the company's continuous improvement program.

# SLIDE LED PATH LIGHT

6311

# WAC

## LANDSCAPE LIGHTING

### Surface Mount Flange/Stake



*Includes three 7 inch threaded stainless steel stabilizing pins for ground mounting or surface mounts with four screws or over a junction box*

**5000-SCP-BZ**  
*Bronze on Aluminum*

### Additional Mounting Stake



**9000-ST9-BK**  
*Durable PVC stake*



### Guardian Mount

*Heavy duty stainless steel spike to position fixture.  
Formed from a single piece of metal*

**9000-SP9-BZ**  
*Stainless Steel*

### Magnetic Transformers

*Stainless Steel, 12-15V output, IP65 rated, UL 1838 listed  
See transformer spec sheet for details and its accessories*

**9075-TRN-SS**  
*75W Max*

**9150-TRN-SS**  
*150W Max*

**9300-TRN-SS**  
*300W Max*

**9600-TRN-SS**  
*600W Max*



waclighting.com  
Phone (800) 526.2588  
Fax (800) 526.2585

Headquarters/Eastern Distribution Center  
44 Harbor Park Drive  
Port Washington, NY 11050

Central Distribution Center  
1600 Distribution Ct  
Lithia Springs, GA 30122

Western Distribution Center  
1750 Archibald Avenue  
Ontario, CA 91760

*WAC Lighting retains the right to modify the design of our products at any time as part of the company's continuous improvement program.*

# SLIDE LED PATH LIGHT

6321

# WAC

## LANDSCAPE LIGHTING

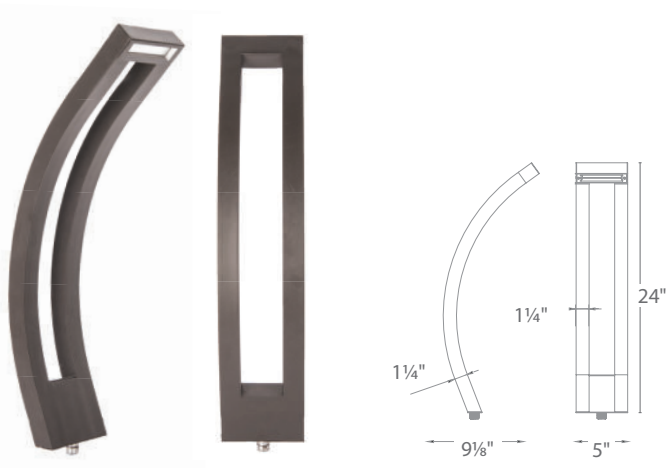

Fixture Type:

Catalog Number:

Project: \_\_\_\_\_

Location: \_\_\_\_\_

### PRODUCT DESCRIPTION

Sleek linear design blends seamlessly into pathways while providing soft, even illumination

### FEATURES

- IP66 rated, Protected against powerful water jets
- Factory sealed water tight fixtures
- Translucent lens provides uniform light distribution
- Constant output for 9V-15V input
- Mounting stake, 6 foot lead wire, and direct burial gel filled wire nuts are included
- Recommended spacing for installation: Residential: 9 to 11ft; Commercial: 5 to 7ft
- Maintains constant lumen output against voltage drop
- UL & cUL 1838 Listed (12V)

### SPECIFICATIONS

**Input:** 9-15VAC (Transformer is required)  
**Power:** 3.0W / 4.5VA  
**Brightness:** Up to 95 lm  
**CRI:** 90  
**Rated Life:** 60,000 hours

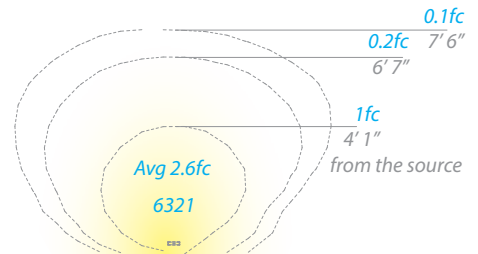

### ORDERING NUMBER

	Color Temp	Finish
<b>6321</b> Large Slide	<b>30</b> 3000K Pure White	<b>BZ</b> Bronze on Aluminum

**6321-\_\_\_BZ**

Example: **6321-30BZ**

wacighting.com  
 Phone (800) 526.2588  
 Fax (800) 526.2585

Headquarters/Eastern Distribution Center  
 44 Harbor Park Drive  
 Port Washington, NY 11050

Central Distribution Center  
 1600 Distribution Ct  
 Lithia Springs, GA 30122

Western Distribution Center  
 1750 Archibald Avenue  
 Ontario, CA 91760

# SLIDE LED PATH LIGHT

6321

# WAC

## LANDSCAPE LIGHTING

### Surface Mount Flange/Stake



*Includes three 7 inch threaded stainless steel stabilizing pins for ground mounting or surface mounts with four screws or over a junction box*

**5000-SCP-BZ**  
*Bronze on Aluminum*

### Additional Mounting Stake



**9000-ST9-BK**  
*Durable PVC stake*



### Guardian Mount

*Heavy duty stainless steel spike to position fixture.  
Formed from a single piece of metal*

**9000-SP9-BZ**  
*Stainless Steel*

### Magnetic Transformers

*Stainless Steel, 12-15V output, IP65 rated, UL 1838 listed  
See transformer spec sheet for details and its accessories*

**9075-TRN-SS**  
*75W Max*

**9150-TRN-SS**  
*150W Max*

**9300-TRN-SS**  
*300W Max*

**9600-TRN-SS**  
*600W Max*



waclighting.com  
Phone (800) 526.2588  
Fax (800) 526.2585

Headquarters/Eastern Distribution Center  
44 Harbor Park Drive  
Port Washington, NY 11050

Central Distribution Center  
1600 Distribution Ct  
Lithia Springs, GA 30122

Western Distribution Center  
1750 Archibald Avenue  
Ontario, CA 91760

*WAC Lighting retains the right to modify the design of our products at any time as part of the company's continuous improvement program.*